

Be FAST



T7700

LEVERLESS

TIRE CHANGER

JohnBean

T7700

INNOVATIVE TOOLS OPTIMUM PROTECTION

The John Bean® T7700 leverless tire changer provides a comprehensive set of tools that make changing a wide variety of tires quick and easy while minimizing the chance of wheel damage. Easily move tires into position with a pedal-operated wheel lift and secure the wheel with an innovative center post clamp that can accommodate a wide variety of wheels and tires.

The Dynamic Bead Breaker system utilizes two synchronized disks that adjust with pneumatic precision to practically eliminate wheel damage and make short work of removing ultra-high-performance and run-flat tires.

Our powerMONT™ tool makes mounting and demounting tires a snap. For high-volume and specialty shops, this is the ultimate productivity workhorse.



LEVERLESS TIRE CHANGER



powerMONT™

Our leverless mounting and demounting tool synchronizes with the dynamic bead breaker location for optimum positioning. Featuring upgraded steel and plastic protection to ensure long-term operation, this innovative system is a perfect tool for RFT, UHP, OEM's and low-aspect-ratio tires.

PROspeed™

The innovative self-adjusting technology provides the optimum torque and maximizes the rotation speed for safe, efficient operation.

DYNAMIC BEAD BREAKER

The precisely controlled synchronized dual-disk system accurately positions both the upper and lower beads while minimizing the chance of wheel damage. Includes an adjustable tilt for tires with stiff sidewall.

CONTROL PANEL

The color-coded control panel is simple to use with tool-matching operation controls.

WHEN GOOD ENOUGH ISN'T ENOUGH, JB.

EXPANDED CAPABILITIES ULTIMATE PRODUCTIVITY

Be FAST

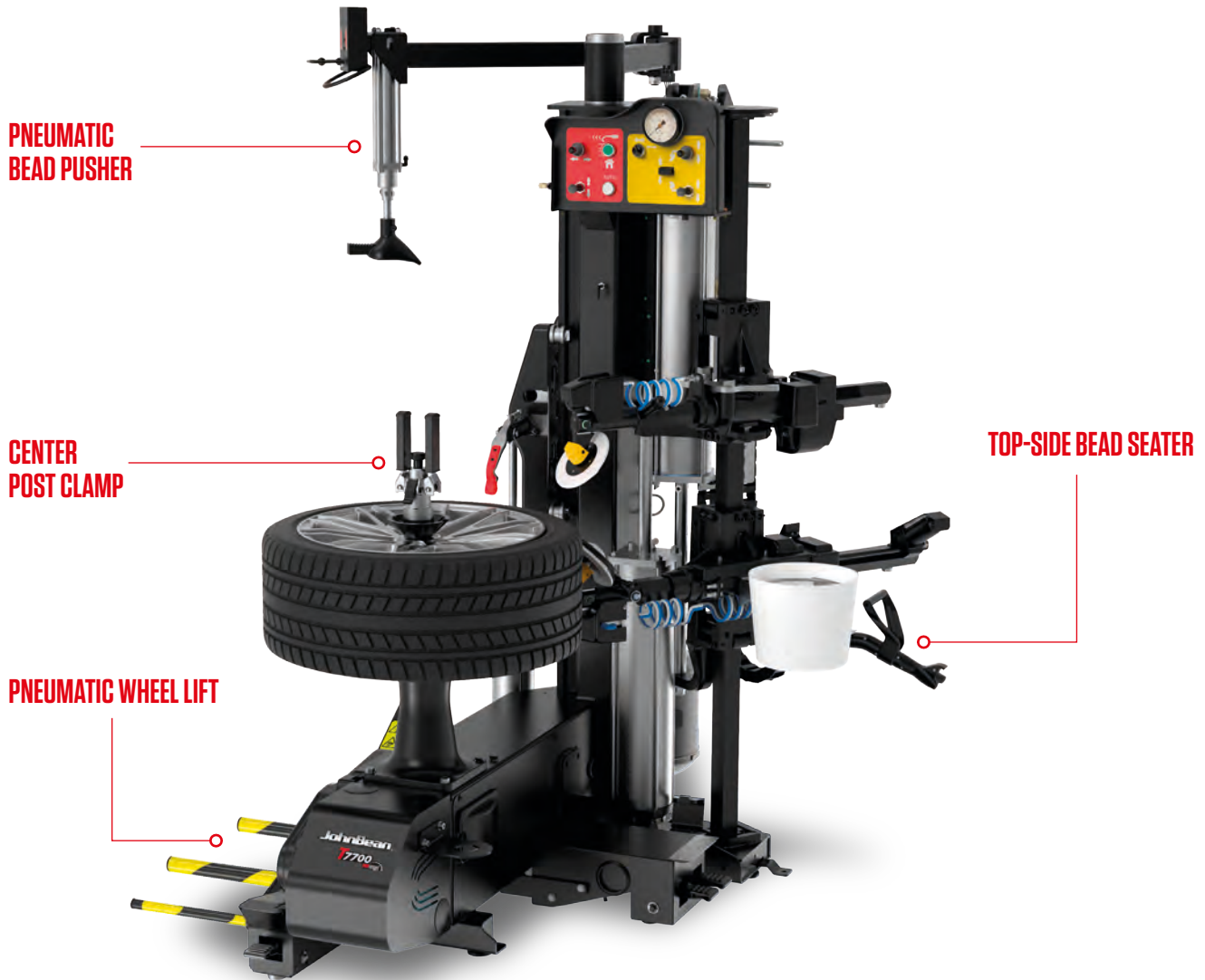

PNEUMATIC WHEEL LIFT

The pedal-operated pneumatic wheel lift assists in lifting heavy wheels to reduce technician fatigue and increase productivity.

CENTER POST CLAMP

The center-post clamp design has numerous benefits, most important is the drastically reduced risk of wheel damage and less clamping restriction than the turntable design.

PNEUMATIC BEAD PUSHER

The Pneumatic Bead Pusher assists in the mounting process of the upper bead. Its dual-purpose design offers a reverse-side hook to help lift heavy tires.

TOP-SIDE BEAD SEATER

This ergonomic hand-held nozzle injects a high-speed blast of air into the tire to raise the bead and seat the tire to the rim.

JohnBean



T7700

TECHNICAL SPECIFICATIONS

Max Rim Diameter	30" 76cm
Max Tire Width	15" 38cm
Max Wheel Diameter	47" 119cm
Wheel Lift Capability	154 lbs. 70 kg
Power Supply	230V 1ph 50-60Hz 16A
Air Pressure Required	116-174 PSI 8-12 bar
Dimensions HxWxD	75"x63"x78" 190x160x198cm

STANDARD ACCESSORIES

- Smart Bead Spacer
- Plastic Rim Protector
- Lube Bucket
- Lube Brush
- Bead Breaker Tool
- Bead Clamp
- Reduction Cones
- Cone Kit
- powerMONT™ Tool Protector

OPTIONAL ACCESSORIES

- Tool Storage
- Universal Reverse Mount Wheel Kit
- 19mm Cylindrical Tip Pins
- Light Truck Wheel Kit



UNITED STATES
800.362.4618

CANADA
800.362.4608



Snap-on® Total Shop Solutions offers a wide range of garage equipment solutions for workshops, garages, car dealers and tire shops, thanks to the specific solutions provided by its portfolio of premium brands. John Bean is a brand of TSS and is committed to product innovation and improvement. Therefore, specifications listed in this sell sheet may change without notice. ©2022 Snap-on Incorporated. John Bean is a trademark, registered in the United States and other countries, of Snap-on Incorporated. All rights reserved. All other marks are marks of their respective holders. ssw19021d (NA en) 12/2022

