

# WORKSHOP EQUIPMENT



WORKSHOP  
EQUIPMENT

Recommended by Volkswagen AG



**Snap-on**

# 3D WHEEL ALIGNER



## VAS 701 001

**Flexible alignment system with plausibility check**

- The aligner is self-calibrating multiple times a second
- The cameras automatically track with the vehicle as it is raised to produce the best accuracy and the most productivity a workshop can have in a wheel aligner
- The aligner is equipped with ride height measurement by using small targets that are easily attached to the wheel well of the vehicle by suction cups. The ride height is now measured and specifications corrected for automatically in the aligner with no manual entry required
- Ultra high resolution cameras to image the four targets mounted on the wheels. The targets are passive which means they do not need power supply or cables. Roll the vehicle back and forward 20 cm and you have toe and camber readings
- The ADR / ACC and other drive assist functions are carried out by an additional digital camera VAS 701 001/1. Supplied as standard.

**Updated via the VW Network**

### Plausibility check

- With new and sophisticated suspension systems in modern vehicles, the accuracy of measurement gets more and more important. To check easily and make sure day by day that your wheel aligner is working properly and according to the given specs use the plausibility check function. This unique software feature enables the operator to check wheel aligner and environment in 4 steps only. On customer request the operator can submit a test report



### Ride height targets

The new ride height targets are stored internally on a vertical pull-out shelf installed in the lower compartment of the cabinet.



# WHEEL BALANCING TECHNOLOGY AT ITS FINEST



## VAS 741 055

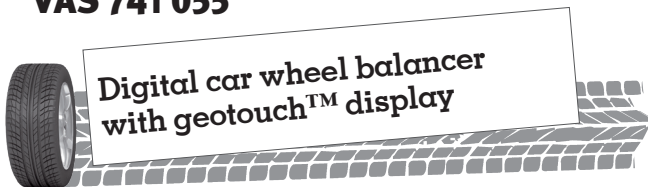

- With torque-controlled Power Clamp device instead of quick nut
- easyWEIGHT™: the pinpoint laser light indicator to accurately and conveniently position adhesive weights
- Stop-in-Position feature where the operator only has to touch the amount of unbalance on the display and the wheel is indexed to correction position
- geoTOUCH™ - the touchscreen graphical display, 10" wide, with DIAMOND user interface – makes VAS 741 055 as intuitive as a video balancer
- Semi-automatic input of offset and rim diameter via 2D SAPE
- Automatic rim width acquisition via Smart Sonar™ – fast and easy
- Semi-automatic pre-selection of balancing mode via easyALU™
- Split weight mode
- Weight minimisation and optimisation
- Two users with rapid switch function
- Network printing capability – Compatible with a network
- Wi-Fi connectivity
- VPM measurement technique for uncompromised accuracy
- QuickBAL™ for reduced measurement time: Short start-stop cycle time: 4.5 seconds (15" rim)



### Power Clamp™

The Power Clamp™ device: effortless, secure, accurate and fast wheel locking.



### Gauge arm

Patented technique for accurate positioning of adhesive wheel weights.

# WHEEL BALANCING TECHNOLOGY AT ITS FINEST



## VAS 741 017

Wheel balancer with  
touchscreen monitor

- Rim scanner for
  - automatic non-contact rim profiling
  - automatic selection of balancing mode and weight position
  - automatic acquisition of rim diameter and offset
- Smart Sonar™ for automatic non-contact acquisition of rim width
- easyWEIGHT™: the pinpoint laser light indicator to accurately position adhesive weights
- geodata® AutoStopSystem for positioning of adhesive weights with patented weight clamp
- Torque-controlled Power Clamp™ device
- Automatic orientation of wheel into correction plane after the measuring run
- VPM measurement technology for uncompromised accuracy
- Telescopic wheel guard – requiring no additional back space
- Rim lighting to facilitate application of the geodata gauge arm
- Imbalance minimisation and optimisation programs
- Network printing capability – compatible with asanetwork

## VAS 741 019

Wheel balancer with  
touchscreen monitor and  
integrated wheel lift

Same as VAS 741 017 with additional integrated wheel lift

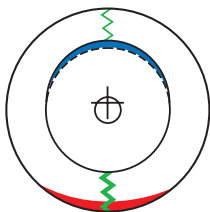

### Optimisation mode

Handles ride issues and  
improves driving comfort.



# TYRE CHANGERS CUSTOM-TAILORED TO SUIT INDIVIDUAL NEEDS

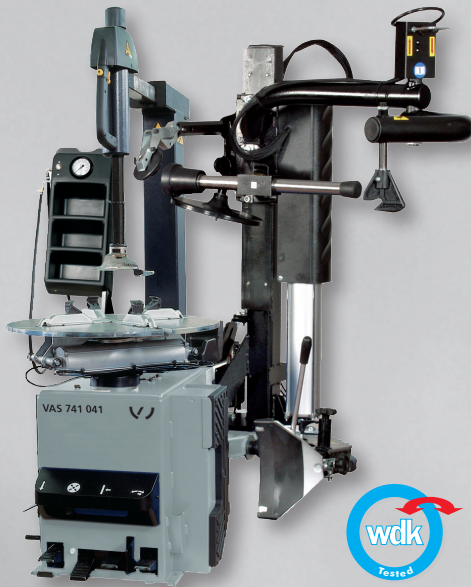

## VAS 741 041

**Pneumatic tilt-back post tyre changer with two speeds**

- smartSpeed™ technology
- Double-acting bead breaker cylinder
- Mounting head adjustable in spaced-apart position relative to the rim
- Mounting/demounting tool (working range 8"–24")
- Turntable with centre-type sliding jaws. Two clamping cylinders provide 30 to 40 % more clamping force than single-cylinder machines
- Pedal-operated pneumatic tilt-back post
- Post pneumatically locked in working position
- On-side bead breaker with adjustable blade inclination for different wheel diameters, adjustable in three positions to grant high performance and flexibility
- Tool box with integrated pressure gauge and four ergonomic shelves for valves, tools and accessories, attached on separate tower
- Pedal-operated inflator with quick-inflating valve

## VAS 741 043

**Tyre changer for wheel width up to 15"**

In addition to the benefits of VAS 741 041 this tyre changer features:

- Mounting and demounting of very wide wheels up to 15"
- The low cabinet offers an ergonomic working height even with very wide wheels
- Vertical positioning of the mounting head is carried out pneumatically – all settings are controlled quickly and ergonomically through a single switch

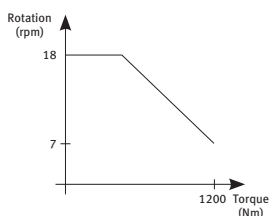

### Special inverter technology

Special inverter technology is the best choice for high-productivity workshops. It provides maximum speed in mounting and demounting operations depending on the torque applied.

# TYRE CHANGERS CUSTOM-TAILORED TO SUIT INDIVIDUAL NEEDS



## VAS 6346 C

Pneumatic tilt-back post tyre changer with outer clamping range of 26"

- Outer clamping range of up to 26" (up to 30" with optional jaws)
- Mounting head pneumatically adjustable in spaced-apart position relative to the rim
- smartSpeed™ technology
- Double-acting bead breaker cylinder
- Bead breaker blade supported in three joints
- Bead breaker adjustable in two ranges
- Pneumatic tool lock and pneumatic tool approach
- Pneumatic tilt-back post, pneumatically locked in working position
- Self-centring four-jaw turntable with sliding jaws
- Pedal-operated inflator with quick-inflating valve
- Tool box with integrated precision pressure gauge

## VAS 741 079

The tyre changer for low-profile, UHP and run-flat tyres

- powerMONT™ the innovative, fast and easy to use lever-less mount/demount system
- smartSpeed™ the exclusive self-adjustable speed system with before up to 20 rpm that provides the optimum torque/speed combination to the chuck
- Dynamic bead breaker with two disks, the solution of choice for RFT and UHP tyres. Precise, ergonomic and effortless
- Manual centre post clamping system
- PBD330, Pneumatic Bead Depressor for convenient demounting of hard sidewall tyres
- High rigidity for safe handling of high-performance tyres
- Pedal-controlled inflator
- Mirror to control operation on the lower bead

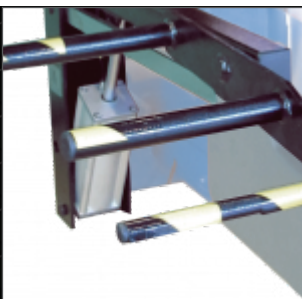

### Wheel lift

Fast and ergonomic. Reduces operator effort in case of large and heavy wheels.



# TYRE CHANGERS CUSTOM-TAILORED TO SUIT INDIVIDUAL NEEDS



## VAS 741 077



- powerMONT™ the innovative, fast and easy to use lever-less mount/demount system
- quickLOK™ automatic centre post clamping system
- smartSpeed™ the exclusive self-adjustable speed system up to 20 rpm that provides the optimum torque/speed combination to the chuck
- Optimum bead breaker system: the high-performance solutions for any tyre types
- Dynamic bead breaker with two disks, the solution of choice for RFT and UHP tyres. Precise, ergonomic and effortless
- On floor bead breaker, the fastest solution for tyres with high aspect ratio
- PBD330, Pneumatic Bead Depressor for convenient demounting of hard sidewall tyres
- Ergonomic wheel lift integrated
- High rigidity for safe handling of high-performance tyres
- Pedal-controlled inflator
- Mirror to control operation on the lower bead



### powerMONT™

The innovative leverless mount/demount system that makes easy working with any type of tyre including RFT, UHP and low aspect ratio ones.

# CONNECTED ROLLER BRAKE TESTER

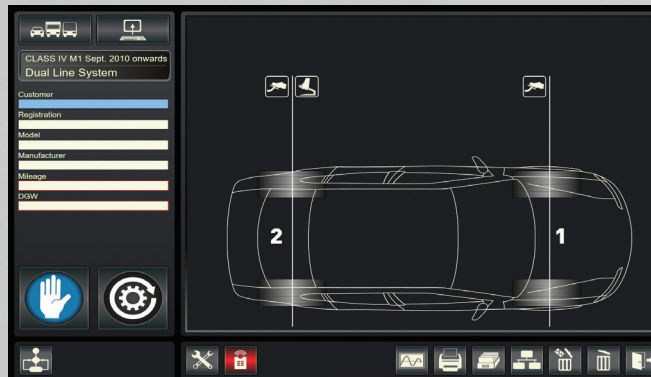

## EEBRGB141A - Class 4 | EEBRGB143A - Class 7\*\*

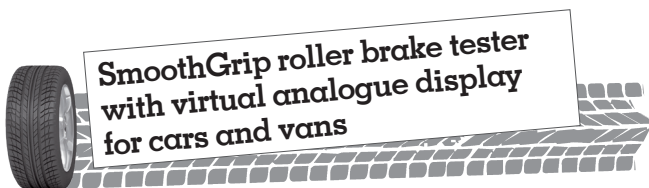

- The Roller brake tester is approved for DVSA “connected” requirements: Connected MoT equipment is able to communicate directly with the DVSA’s MTS system to reduce/eliminate data entry errors.
- Sun Brake Testers are supplied with a 27” monitor, printer and database for saving test results as standard.
- The roller brake surface includes a 10-year warranty, giving you long-term peace of mind.
- Modular configuration for customised solutions and easy hardware upgrade
- User-friendly intuitive graphical user interface in an attractive design

- 15 meter communication cable as standard enables convenient positioning of display monitor. (Optional 25 meter cable available, sold separately)
- 27” virtual analogue display
- Prints and stores graphical data results
- Steel rollers in SmoothGrip design
- Easy exiting from rollers with motor brakes
- Dual direction testing
- Roller covers as standard
- Automatic axle weighing
- UK MOT/ATL approved

\*\*Note, this is available as Class 4 & class 7

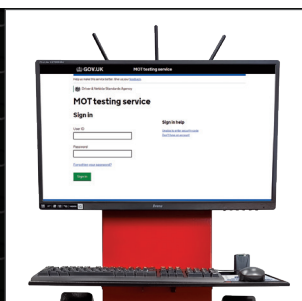

Compatible with Sun DGA6000 Link Emissions Analyser.  
Sold separately.



# LIFTING TABLE FOR ELECTRIC AND HYBRID VEHICLE BATTERIES



## EELS735A - Electric and Hybrid Vehicle Battery Lift - 1200kg

 Dedicated lifting table to demount/mount the battery from underneath an electric or hybrid vehicle

- Two lifting modes for standard and slow lifting
- Electrically released mechanical locking system
- Hand-held lift controls with stop, slow rise, standard rise, and down functions
- The suspend platform can tilt within a height of 40mm. The lower platform can move laterally within a distance of 20mm
- Reserved holes (100mm x100mm) on the working table for positioning and fixing components with specialized fixtures
- Can also be used to demount engine, gearbox, drive axle, fuel tank and suspension of petrol- and diesel-powered vehicles.
- Oil hose with double steel wire fabrications, which has passed pressure test under 40MPa, can work under twice the nominal working pressure without breakage.
- Pins and pads for positioning and fixing components



Hand-held control unit with stop function



A dual-speed system for fast and precise lifting



Extendable platform

# ACCESSORIES

A choice of accessories for the VAS wheel balancers in this catalogue

Car wheels		Light-truck wheels			
	4029029	Stud-hole flange FP VAG For Volkswagen, Audi, Seat and Skoda Pitch circle diameters: 5 x 100/112/120/130 mm; 5 x bolts 80 mm		24936	Centring cone Ø 113–170 mm For steel and alloy rims with centre bore of Ø 114–169 mm, on the condition the centre bore outer side is machined sufficiently accurate. To be applied only from the outside and in conjunc- tion with spacer ring 24937
	4028856	Centring & clamping kit – Porsche STANDARD Consisting of tapered centring ring C Ø = 7.5–74.2 mm, clamping ring		25790	Centring cone Ø 195–214 mm For light-truck rims, steel rims with centre bore of Ø 196–213 mm. For wheels of less than 65 kg and for maximum overall diameter of 900 mm. To be applied only from the outside and in conjunction with spacer ring 24937
	4030969	Centring & clamping kit – Porsche GT2/GT3/ Turbo Consisting of clamping ring, Porsche centring ring Ø = 84 mm For Porsche rims with central nut on Porsche GT2/GT3/Turbo		24937	Spacer ring (plastic) For light-truck rims which are clamped using special centring cones ref. no. 24936 and 25790, or using a stud- hole flange
	30344	Centring ring Ø1 = 57 mm, Ø2 = 71.6 mm For VW, Audi, Porsche		35382	Centring set VW Crafter Pitch circle diameter 6 x 130 mm
	26445	Tapered centring ring A Ø = 56.5–58.6 mm		35383	Centring set VW Crafter Pitch circle diameter 6 x 205 mm
	26447	Tapered centring ring C Ø = 71.5–74.2 mm For Audi Q7 and Porsche		4026401	Light-truck kit To handle light-truck wheels; consisting of spacer ring and cone 122–172 mm
	26449	Tapered centring ring E Ø = 65.9–67.7 mm			
	26451	Tapered centring ring G Ø = 54.5–56.2 mm			
	26452	Tapered centring ring H Ø = 52–54.2 mm			
	30348	Tapered centring ring I Ø = 66.5 mm For Audi A5 2010+ ; all models except Q7			



# ACCESSORIES

A choice of accessories for the VAS tyre changers in this catalogue

## Car tyres – VAS 741 041, VAS 741 043 and VAS 6346 C

	4029455	+4" adaptors for sliding jaws To increase the outer clamping range by 4", while reducing maximum rim width by 1 1/2"; 1 set = 4 jaws
---	---------	--

	4030319	Kit of plastic protectors for mounting head 5 rim protectors, 5 rear protectors, 2 screws
---	---------	--

## Light-truck tyres – VAS 741 041, VAS 741 043 and VAS 6346 C

	4027629	Adaptors for light-truck wheels, 17.5" 1 set = 4 jaws
--	---------	--

	EAK-0279G86A	Wheel lift for VAS 741 041
	EAK-0279G86A	Wheel lift for VAS 741 043
	EAK-0279G87A	Wheel lift for VAS 6346 C

## Light-truck tyres – VAS 741 077 and VAS 741 079

	4030486	Light-truck wheel kit To clamp pick-up, light-van and light-truck wheels
--	---------	---

	EAK-0317G76A	Cone kit 75 mm Centring cones, 75 mm diameter, for wheel clamping. 1 set = 5 plastic cones
---	--------------	---

	EAK-0317G77A	Cone kit 126 mm Centring cones, 126 mm diameter, for wheel clamping. 1 set = 5 plastic cones.
---	--------------	--

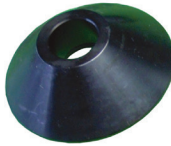
	EAK-0317G78A	Cone kit 145 mm Centring cones, 145 mm diameter, for wheel clamping. 1 set = 5 plastic cones.
--	--------------	--

A choice of accessories for the Lifting table for electric vehicles in this catalogue

## Battery Lift Adaptors - MBL 1200

	EE 792281002	Battery Lift Adaptors - MBL 1200
---	--------------	----------------------------------

# TECHNICAL DATA

Tyre changers		VAS 741 041	VAS 741 043	VAS 6346 C	VAS 741 077	VAS 741 079
Inner clamping range	inch	12–24	12–24	14–26	–	–
Outer clamping range	inch	10–24	10–24	12–26	–	–
Clamping range	inch	–	–	–	12–30	12–30
Max. rim width	inch	12	14	16	13	13
Max. tyre width	inch	13	15	17	15	15
Max. wheel diameter	mm	1000	1000	1200	1200	1200
Max. wheel weight	kg	70	70	70	70	70
Max. bead breaking width	mm	392	392	410	-	-
Dimensions (W x D x H)	mm	1220x1700x1870	1350x1800x1920	1720x1920x2260	1481x1863x1880	1481x1863x1880
Weight	kg	300	310	440	465	420
Compressed air supply	bar	8–12	8–12	8–12	8–12	8–12
Power supply		230 V 1ph 50/60 Hz	230 V 1ph 50/60 Hz	230 V 1ph 50/60 Hz	230 V 1ph 50/60 Hz	230 V 1ph 50/60 Hz
Turntable speed	rpm	7/7-18	7/7-18	7/7-14	7-20	7-20

Wheel balancers		VAS 741 055
Rim centre bore diameter	mm	43–116
Measuring speed	rpm	> 200
Input:		
– Rim width (auto)	inch	1–20 (3–15)
– Rim diameter (auto)	inch	8–25
– Rim diameter (man)	inch	8–32
Max. wheel width	mm	508
Max. wheel diameter	mm	1050
Max. wheel weight	kg	70
Dimensions (W x D x H)	mm	1838x878x1834
Weight	kg	140
Power supply		230V, 1 ph / 50/60 Hz



# TECHNICAL DATA

Wheel balancers		VAS 741 017	VAS 741 019
Rim centre bore diameter	mm	43–116	43–116
Measuring speed	rpm	> 200	> 200
Input:			
– Rim width (auto)	inch	1–20 (3–15.8)	1–20 (3–15.8)
– Rim diameter (auto)	inch	14–26	14–26
– Rim diameter (man)	inch	8–32	8–32
Max. wheel width	mm	508	508
Max. wheel diameter	mm	1050	1050
Max. wheel weight	kg	70	70
Dimensions (W x D x H)	mm	1940x1020x1570	1940x1020x1570
Weight	kg	160	170
Power supply		230V, 1 ph / 50/60 Hz	230V, 1 ph / 50/60 Hz

Wheel aligner VAS 701 001	Measuring range	Resolution
Single wheel toe – front/rear end	± 35°	1'
Total toe – front/rear end	± 60°/40°	1'
Max. steering angle	50°	1'
Camber – front/rear end	± 55°	1'
Caster – front end	± 30°	1'
Steering axis inclination	± 30°	1'
Thrust angle	± 35°	1'

Electric Vehicle Battery Lift - MBL 1200	
Lifting capacity	1200kg
Lifting height	1800mm
Working table dimensions	1.741mm -2.051mm x 850 mm Extensions of 310mm in length Extendable, moving and titling platform
Base to floor clearance	196mm
Voltage	220V
Control voltage	24V Three-pin plug

# QUALITY AND SERVICE YOU EXPECT FROM A HIGHLY COMMENDED AND TRUSTED BRAND

When you are considering renewing or modernising equipment in your workshop, we have the products and services you need. We can provide reliable and profitable solutions for your garage equipment needs, all backed up with the best support in the industry.

## WE'RE READY TO SOLVE YOUR QUERIES

via our dedicated in-house support team



Our UK call centre team have **decades of experience within the automotive industry** and are equipped to troubleshoot your queries quickly.

## NATIONWIDE SERVICE COVERAGE

Over 40 UKAS and GEA accredited engineers



We provide calibration and routine maintenance to keep your investment in the best working condition.

## AT SNAP-ON, WE ARE PASSIONATE ABOUT OUR AFTER-CARE SERVICE



Over the last five years, we have sent out more than 20,000 customer surveys to help us understand how you feel about your Snap-on support. We are proud to announce that 93% of our customers have said we met or exceeded their expectations.

**For more information about any of our products or services contact us on 07557 188 760 to arrange a Technical Sales Representative visit**



